

# 7.3 Meter Cassegrain Antenna

## Antenna Technologies



### Overview

The CPI Antenna Technologies' 7.3 meter antenna delivers exceptional performance for transmit/receive and receive only applications for L through DBS Band frequencies. This antenna offers a reflector design that incorporates precision-formed panels, contoured radials and a machined hub assembly.

It features an innovative Cassegrain feed and subreflector design which results in high gain, low noise temperature, high antenna efficiency and excellent rejection of noise and microwave interference. A large center hub provides spacious accommodation for equipment mounting. The reflector is supported by a galvanized Kingpost pedestal that provides the required stiffness for pointing and tracking accuracy. The pedestals are designed for full orbital arc coverage and are readily adaptable to ground or rooftop installations.

The electrical performance is compliant with FCC and ITU-RS-580 sidelobe specifications and Intelsat (F3, E3) and Eutelsat (L, S1) requirements. All configurations meet our own type-approved quality assurance and performance guarantee.

### FEATURES:

- Bolt-together, all-aluminum reflector with self-aligning, fully interchangeable components
- Designed for 1.5 to 31 GHz operation, meeting FCC 25.209 and ITU-RS-580 regulations
- Galvanized steel elevation-over-azimuth pedestal with jackscrews
- Survives 125 mph winds in any position

### OPTIONS:

- L, S, C, X, Ku and DBS Ka-Band feeds
- C/Ku receive only feed systems
- Specialized feed systems (e.g., extended, multi-band)
- Antenna control system with tracking
- Reflector and feed deicing systems
- Environmental hub configurations
- Integrated transmit cross axis kits
- Integrated LNA or LNB systems
- HPAs, converters and M&C systems
- Load frame mounts
- Packing for sea and air transport
- Turnkey installation and testing

### UPGRADES:

- Extended azimuth travel
- Low operating temperatures
- High power configurations

### BENEFITS:

- High antenna efficiency
- Excellent rejection of noise and microwave interference

### APPLICATIONS:

- Communications, Data Transfer, Broadcast

# 7.3 Meter Cassegrain Antenna

## Specifications

ELECTRICAL <sup>(1)</sup>	C-Band 4 Port Circular Polarized		Ext. C-Band 4 Port Linear Polarized		Ext. Ku-Band 4 Port Linear Polarized		Ka-Band 4 Port Circular Polarized	
	Receive	Transmit	Receive	Transmit	Receive	Transmit	Receive	Transmit
Frequency (GHz)	3.400- 4.200	5.725 - 6.725	3.400 - 4.200	5.725 - 6.725	10.700 - 12.750	13.750 - 14.800	17.700 - 22.000	27.700 - 31.000
Antenna Gain, Midband dBi <sup>(2)</sup>	46.80	52.20	46.60	51.70	55.70	58.30	61.20	63.60
VSWR	1.30:1	1.30:1	1.30:1	1.30:1	1.30:1	1.30:1	1.30:1	1.30:1
Pattern Beamwidth <sup>(2)</sup>								
-3 dB, at midband	0.63°	0.43°	0.67°	0.44°	0.23°	0.20°	0.13°	0.10°
-15 dB, at midband	1.32°	0.90°	1.41°	0.92°	0.48°	0.42°	0.27°	0.21°
Antenna Noise Temperature								
5° Elevation	66 K		54 K		92 K		189 K	
10° Elevation	57 K		45 K		78 K		151 K	
20° Elevation	50 K		40 K		70 K		124 K	
40° Elevation	47 K		38 K		66 K		107 K	
Typical G/T (dB/K) <sup>(3)</sup>								
(4.000 GHz, 30°K LNA)	29.3		29.5					
(4.000 GHz, 50°K LNA)	28.4		28.5					
(11.725 GHz, 70°K LNA)					35.2			
(11.725 GHz, 90°K LNA)					34.4			
(19.850 GHz, 120°K LNA)							37.3	
(19.850 GHz, 200°K LNA)							36.1	
Axial Ratio (dB)	0.50 dB	0.50 dB					0.50 dB	0.50 dB
Power Handling (total)		5 kW CW		10 kW CW		2 kW CW		500 Watt
Cross Polarization Isolation (dB)								
On Axis	30.8 dB	30.8 dB	35.0 dB	35.0 dB	35.0 dB	35.0 dB	30.8 dB	30.8 dB
Within a 1.0 dB Beamwidth	30.8 dB	30.8 dB	30.0 dB	30.0 dB	35.0 dB	35.0 dB	30.8 dB	30.8 dB
Port-to-Port Isolation (dB)								
Rx/Tx (Rx frequency)	0 dB	-85 dB	0 dB	-85 dB	0 dB	-70 dB	0 dB	-85 dB
Tx/Rx (Tx frequency)	-85 dB	0 dB	-85 dB	0 dB	-85 dB	0 dB	-85 dB	0 dB
RX/RX TX/TX							16.0 dB	16.0 dB
Sidelobe Performance	Meets ITU-RS-580, FCC							
RF Specification	975-5035		975-5022		975-5079		975-5377	

<sup>(1)</sup> All values are at rear feed flange. <sup>(2)</sup> C-Band Rx values are at 4 GHz. <sup>(3)</sup> Typical G/T at 20° elevation with clear horizon using single bolt-on LNA feed.

### Notes - Other operational frequencies available

- 10% of sidelobes may exceed the sidelobe specifications where applicable.
- Power handling capability is based on and limited by the physical characteristics in the feed components. Microwave power at these levels may contribute to the radiation hazard or exceed certain off axis EIRP specifications.

# 7.3 Meter Cassegrain Antenna

## Specifications

MECHANICAL/ENVIRONMENTAL <sup>(4)</sup>		Kingpost Pedestal (KX200)	Turning Head (TH)	KXKA	High Wind (HW)
Antenna Diameter		7.3 meters (24 feet)			
Antenna Type		Cassegrain design			
Reflector Construction		20 precision-formed aluminum panels with heat-diffusing white paint Cleaned and brightened aluminum back-up structure			
Hub Dimensions		60 in (152 cm) OD, 36 in (91 cm) depth	60 in (152 cm) OD, 36 in (91 cm) depth	75 in (191 cm) OD, 36 in (91 cm) depth	60 in (152 cm) OD, 36 in (91 cm) depth
Mount Configuration		Elevation over azimuth pedestal, constructed of galvanized steel			
Drive Type		Manual jack screw 200° in	EL Jack / AZ Gear 240° continuous	Manual jack screw 200° in	Manual jack screw 200° in
Azimuth Travel		2 segments of 120°		2 segments of 120°	2 segments of 115°
Elevation Travel		0 to 90° continuous	0 to 90° continuous	0 to 90° continuous	0 to 90° continuous
Pol Travel <sup>(5)</sup>		+/- 90°	+/- 90°	+/- 90°	+/- 90°
Foundation (L x W x D)		16.5 x 16.5 x 2 ft (5.0 x 5.0 x 0.61 m) 27 cubic yards	22 x 22 x 1.5 ft (6.7 x 6.7 x 0.48 m) 27 cubic yards	22 x 22 x 1.5 ft (6.7 x 6.7 x 0.48 m) 27 cubic yards	26.5 x 26.5 x 2.5 ft (6.7 x 6.7 x 0.48 m) 65 cubic yards
	Concrete Reinforcing Steel Subbase	2966 lbs (1345 kgs) 2000 PSF	2966 lbs (1345 kgs) 2000 PSF	3560 lbs (1615 kgs) 2000 PSF	8335 lbs (3781 kgs) 3000 PSF
Weights	Reflectors Pedestals	2200 lbs (998 kgs) 2000 lbs (907 kgs)	2200 lbs (998 kgs) 6500 lbs (2948 kgs)	2420 lbs (1098 kgs) 3200 lbs (1451 kgs)	2420 lbs (1098 kgs) 3200 lbs (1451 kgs)
Shipping Containers		One 40 ft standard container	Two 40 ft standard containers	One 40 ft standard container	One 40 ft standard container
Wind Loading	Operational	45 mph (72 km/h) gusting to 62 mph (100 km/h)	45 mph (72 km/h) gusting to 62 mph (100 km/h)	45 mph (72 km/h) gusting to 62 mph (100 km/h)	Up to 62 mph (100 km/h)
	Survival	125 mph (200 km/h)	125 mph (200 km/h)	125 mph (200 km/h)	150 mph (241 km/h), any position 200 mph (321 km/h), stow survival
Temperature	Operational Survival	+5° to +122°F (-15° to +50° C) -22° to +140°F (-30° to +60° C), low temperature options available			
Rain		Up to 4 in/h (10 cm/h)			
Relative Humidity		0 to 100% with condensation			
Solar Radiation		360 BTU/h/ft <sup>2</sup> (1,000 Kcal/h/m <sup>2</sup> )			
Ice	Survival	1 in (2.5 cm) on all surfaces or 1/2 in (1.3 cm) on all surfaces with 80 mph (130 km/h) wind gusts			
Atmospheric Conditions		As encountered in coastal regions and/or heavily industrialized areas			
Shock and Vibration		As encountered during shipment by airplane, ship or truck			

<sup>(4)</sup> Some specifications may vary based on the combination of equipment, options and/or upgrades ordered.

<sup>(5)</sup> Polarization drive can mechanically travel +/- 90°. Final Polarization travel will depend on the design of the integrations and RF electronics/plates. Most CPI designs using all CPI products and electronics are designed to travel +/- 90° for standard products.

# 7.3 Meter Cassegrain Antenna

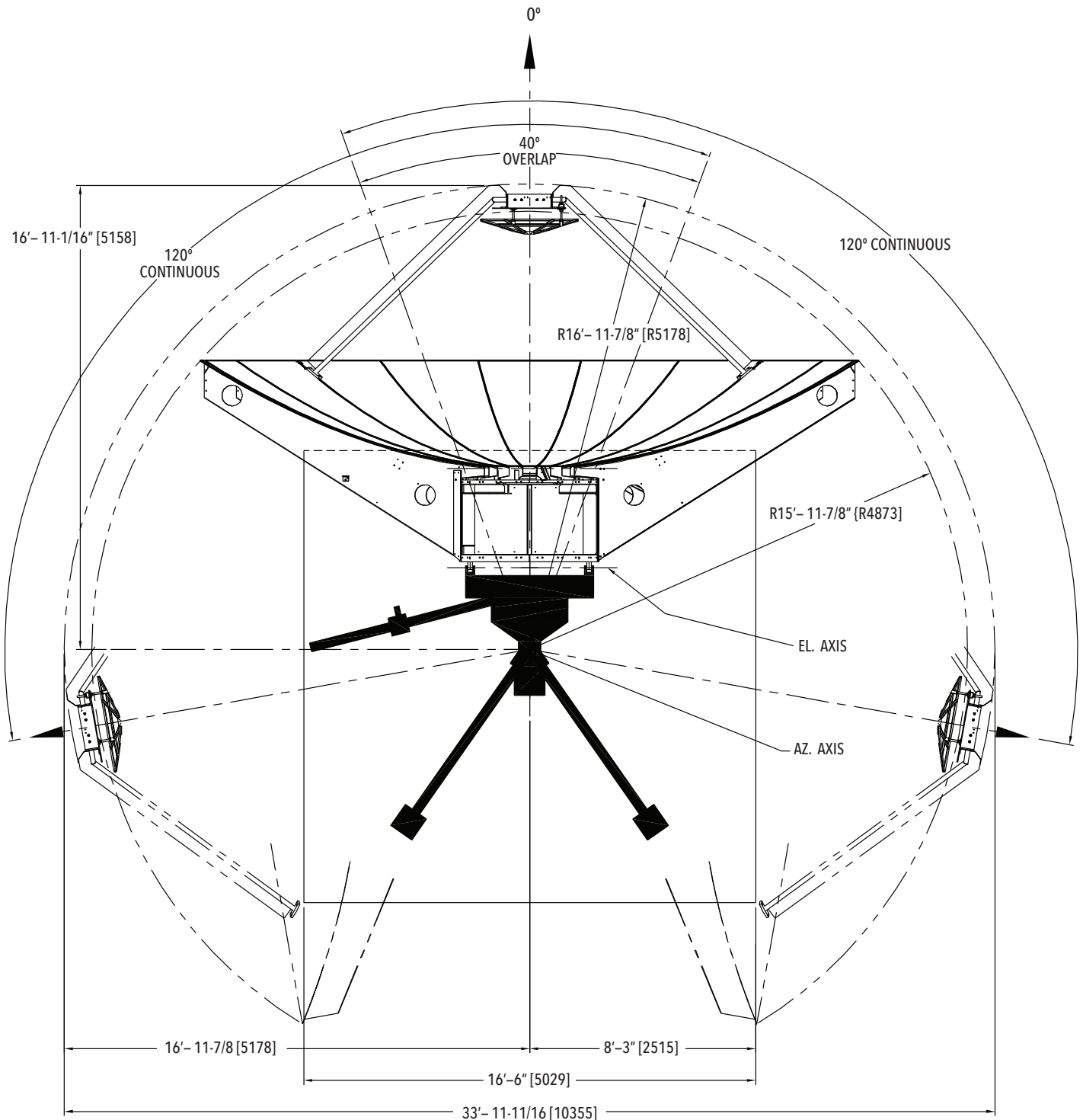

PLAN VIEW

ANT GEOMETRY 200° AZ 7.3 M

# 7.3 Meter Cassegrain Antenna

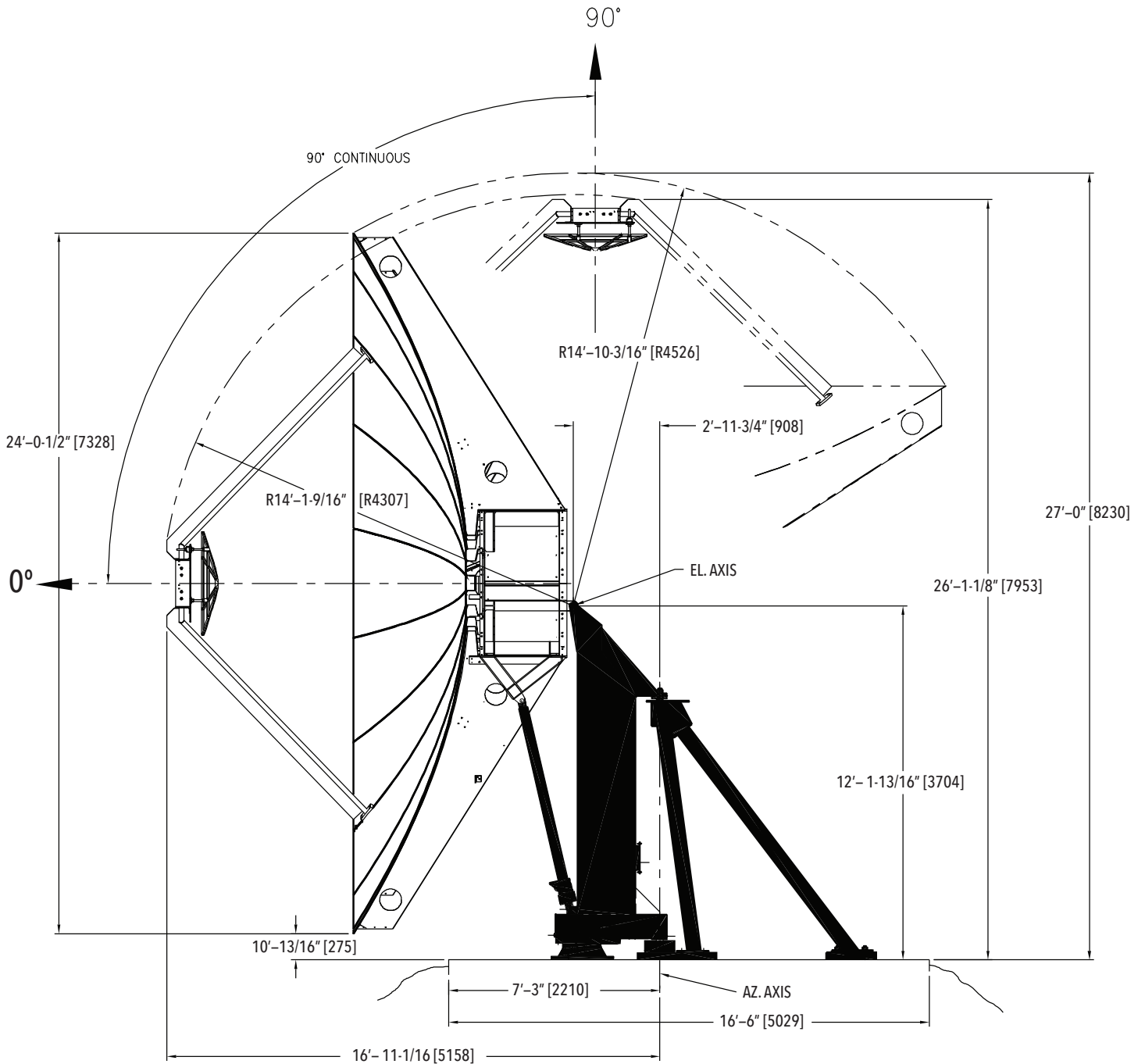

**SIDE ELEVATION**

**ANT GEOMETRY 200° AZ 7.3 M**

# 7.3 Meter Cassegrain Antenna

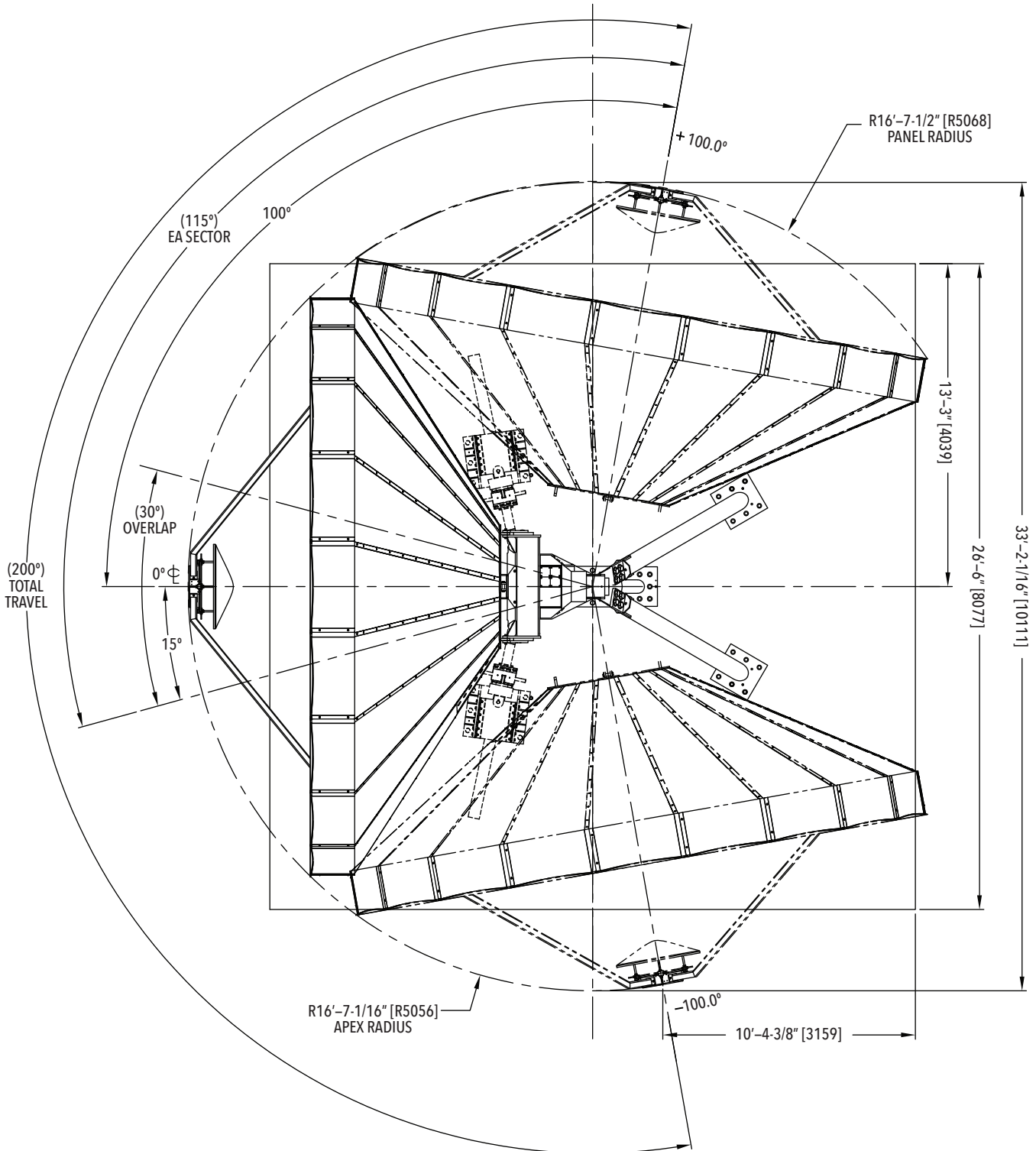

**PLAN VIEW**

**7.3 M KX HW 200° AZ TRV**  
**115°/SECTOR 0-90° EL**

# 7.3 Meter Cassegrain Antenna

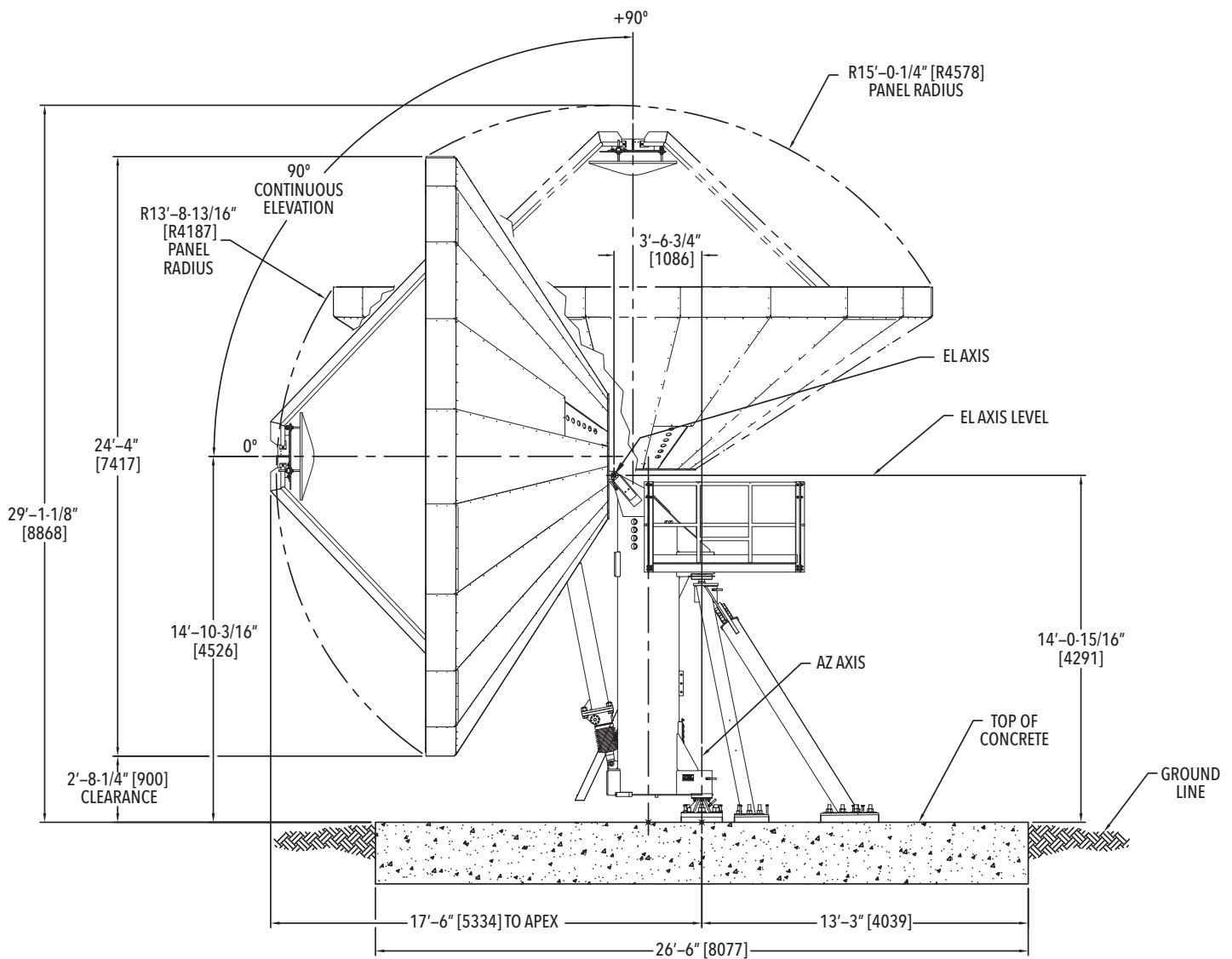

## SIDE ELEVATION

### 7.3 M KX HW 180° AZ

Contact us at [CustomerCareSAT@cpii.com](mailto:CustomerCareSAT@cpii.com) or call us at +1 770-689-2040

The data should be used for basic information only.  
 Formal, controlled specifications may be obtained from CPI for use in equipment design.



**Antenna Technologies**  
 2600 N Longview St.  
 Kilgore, TX  
 USA 75662

+1 770-689-2040  
 1 888-874-7646  
 (In North America)  
 1 619-240-8480  
 (Outside North America)

[CustomerCareSAT@cpii.com](mailto:CustomerCareSAT@cpii.com)  
[www.cpii.com](http://www.cpii.com)

For more detailed information, please refer to the corresponding CPI technical description if one has been published, or contact CPI. Specifications may change without notice as a result of additional data or product refinement. Please contact CPI before using this information for system design. © 2023 Communications & Power Industries LLC. Company proprietary; use and reproduction is strictly prohibited without written authorization from CPI.

©2023 Communications & Power Industries LLC. Company proprietary; use and reproduction is strictly prohibited without written authorization from CPI.